

1.1, BricklesDefinitions

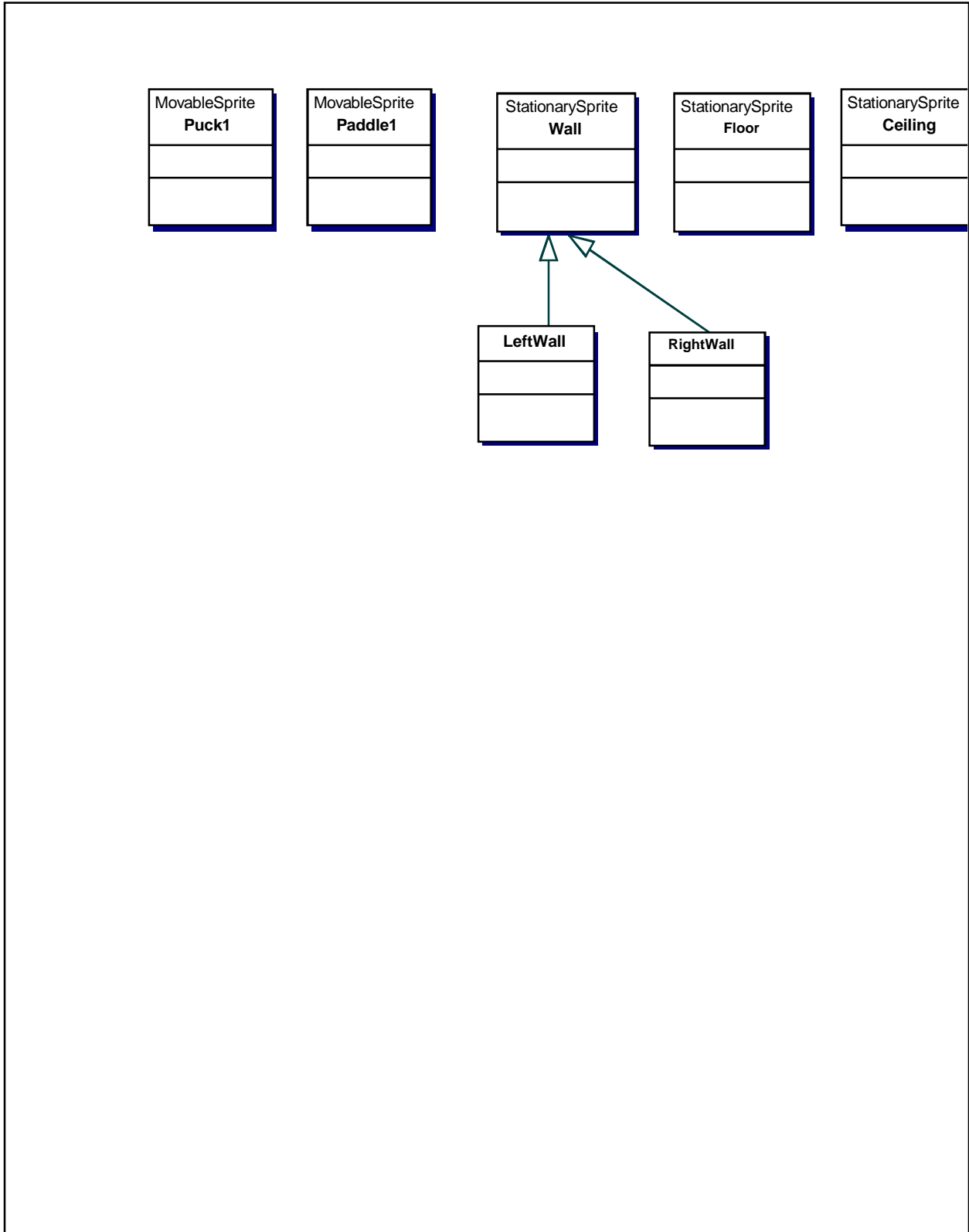

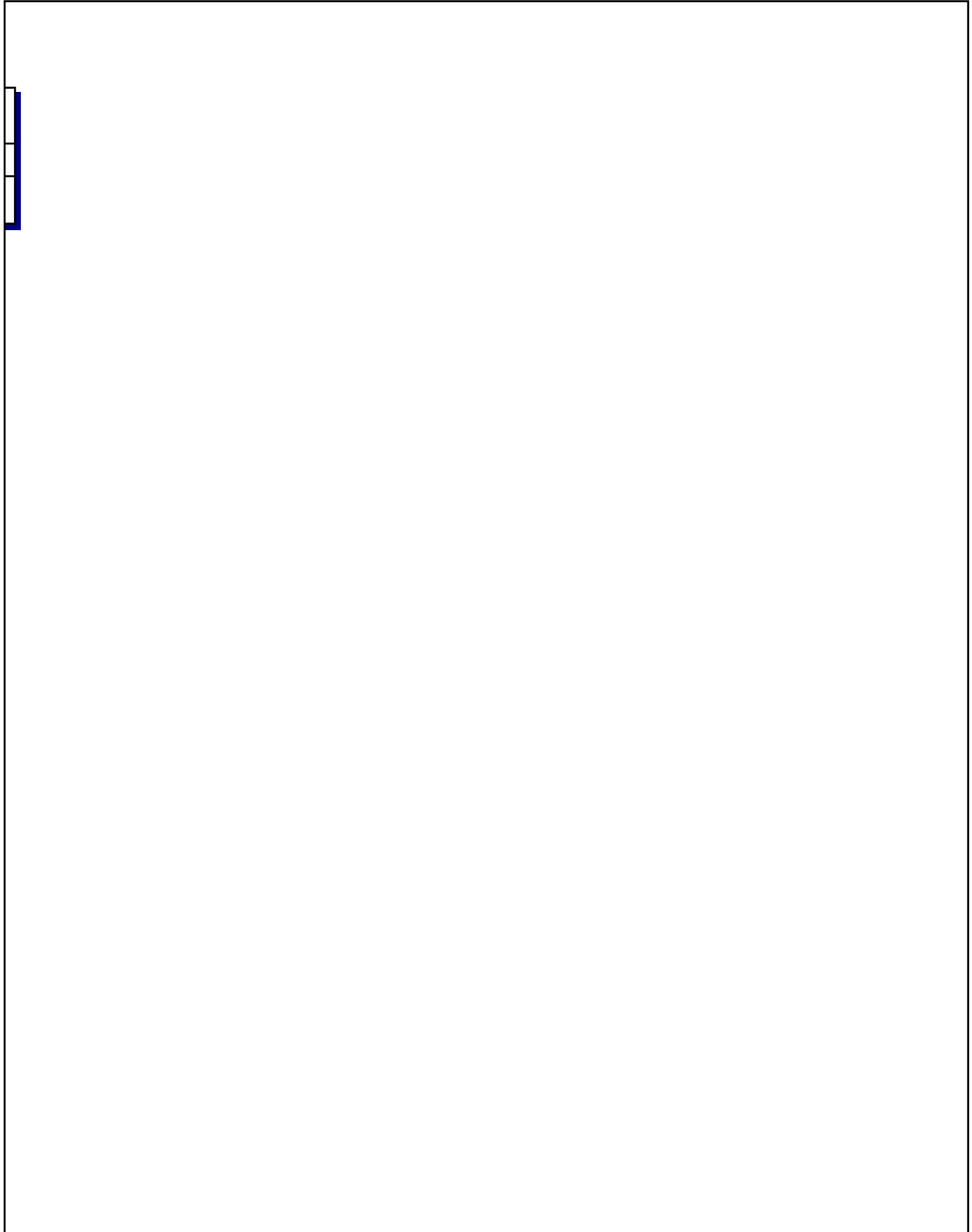

1.1, Component

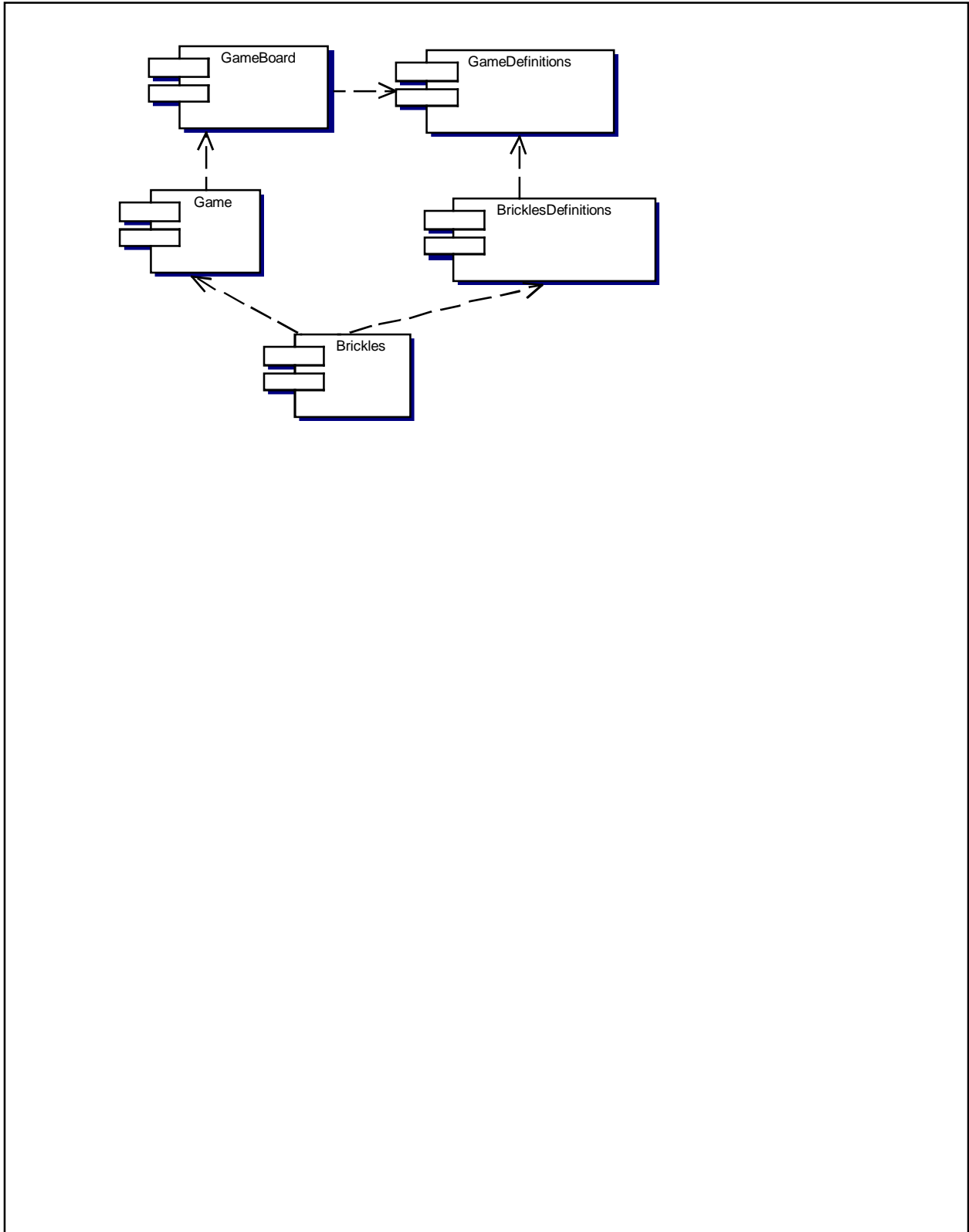

1.1, Component

1.2, <default>

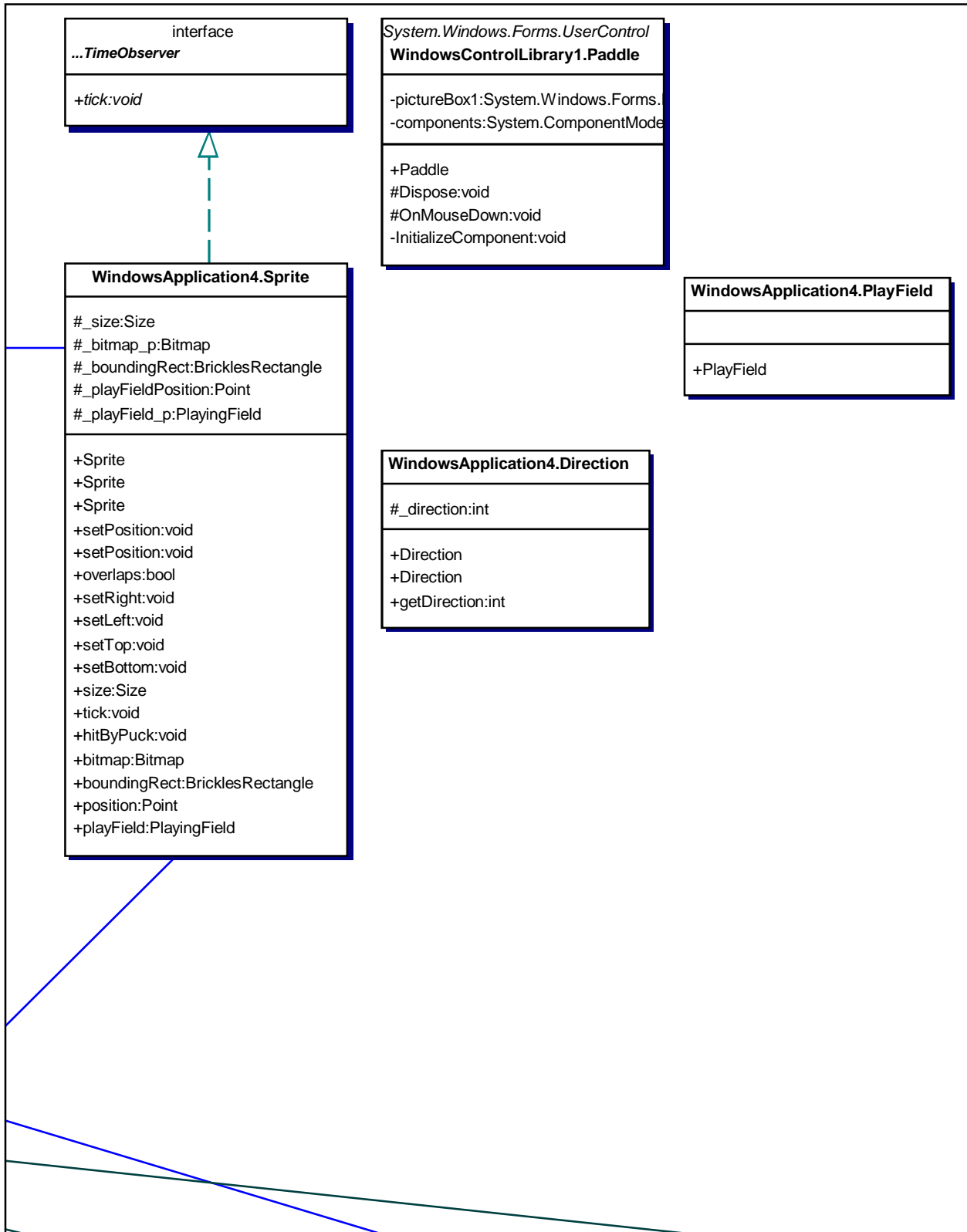

1.2, <default>

1.3, <default>

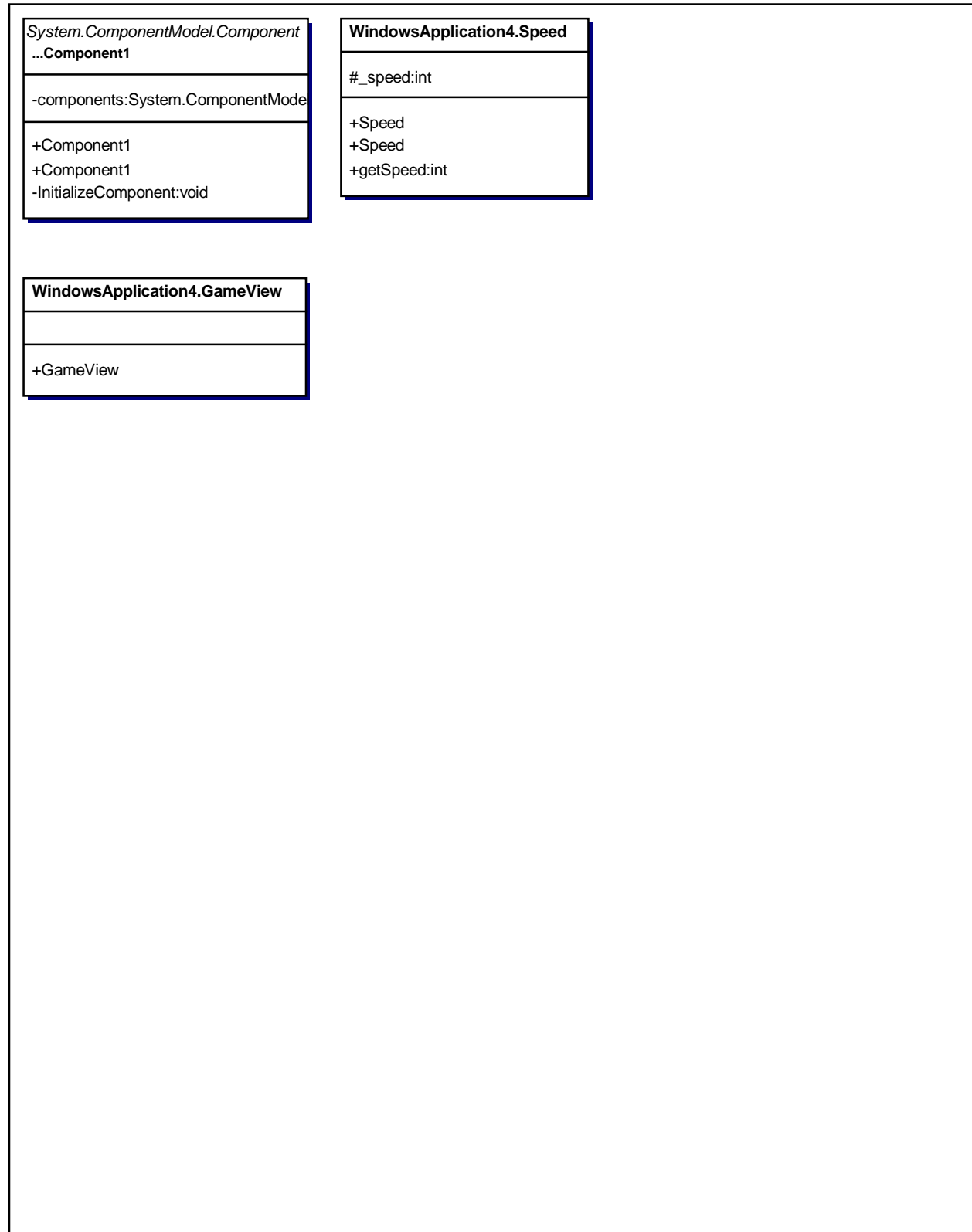

1.3, <default>

2.1, <default>

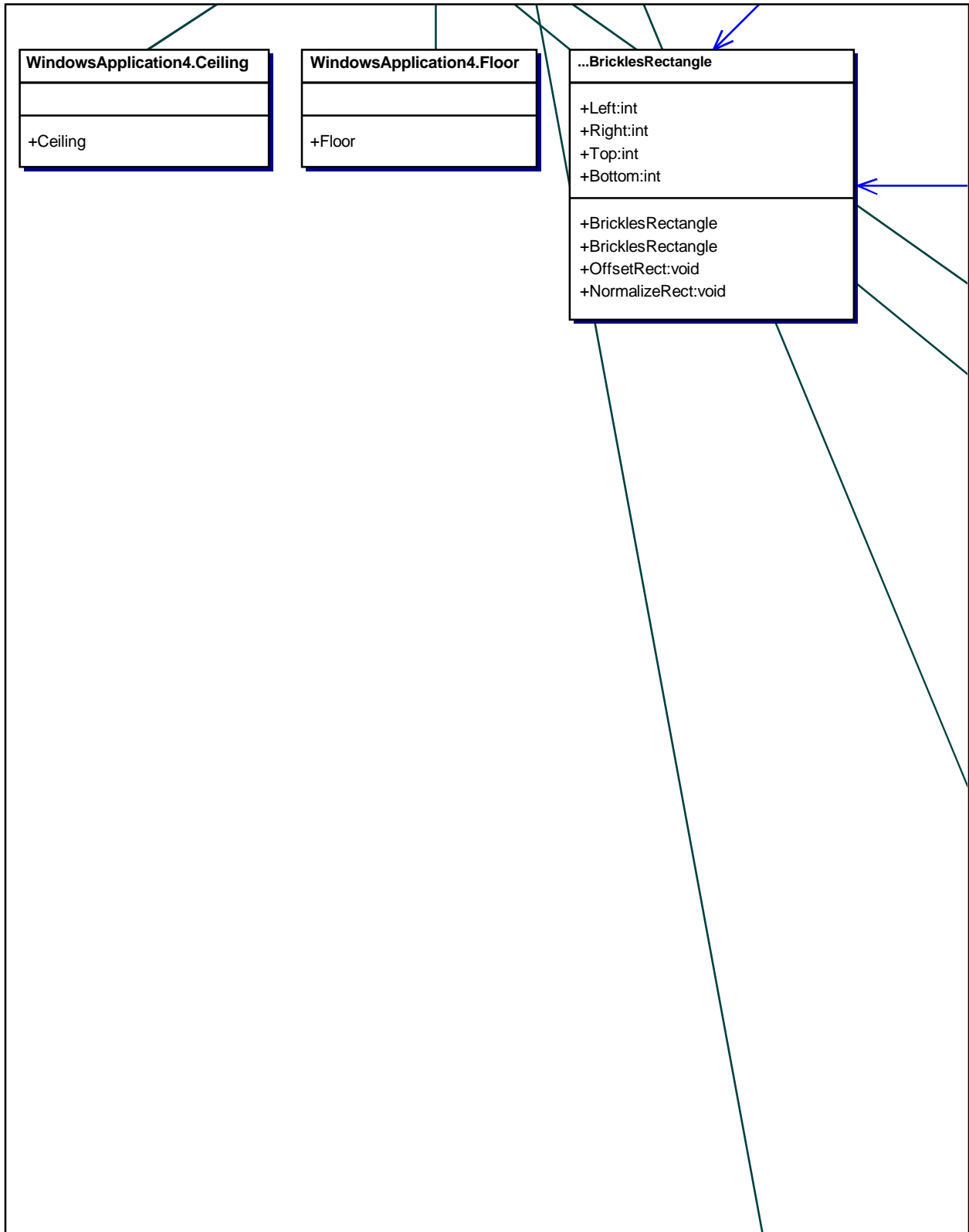

2.1, <default>

2.2, <default>

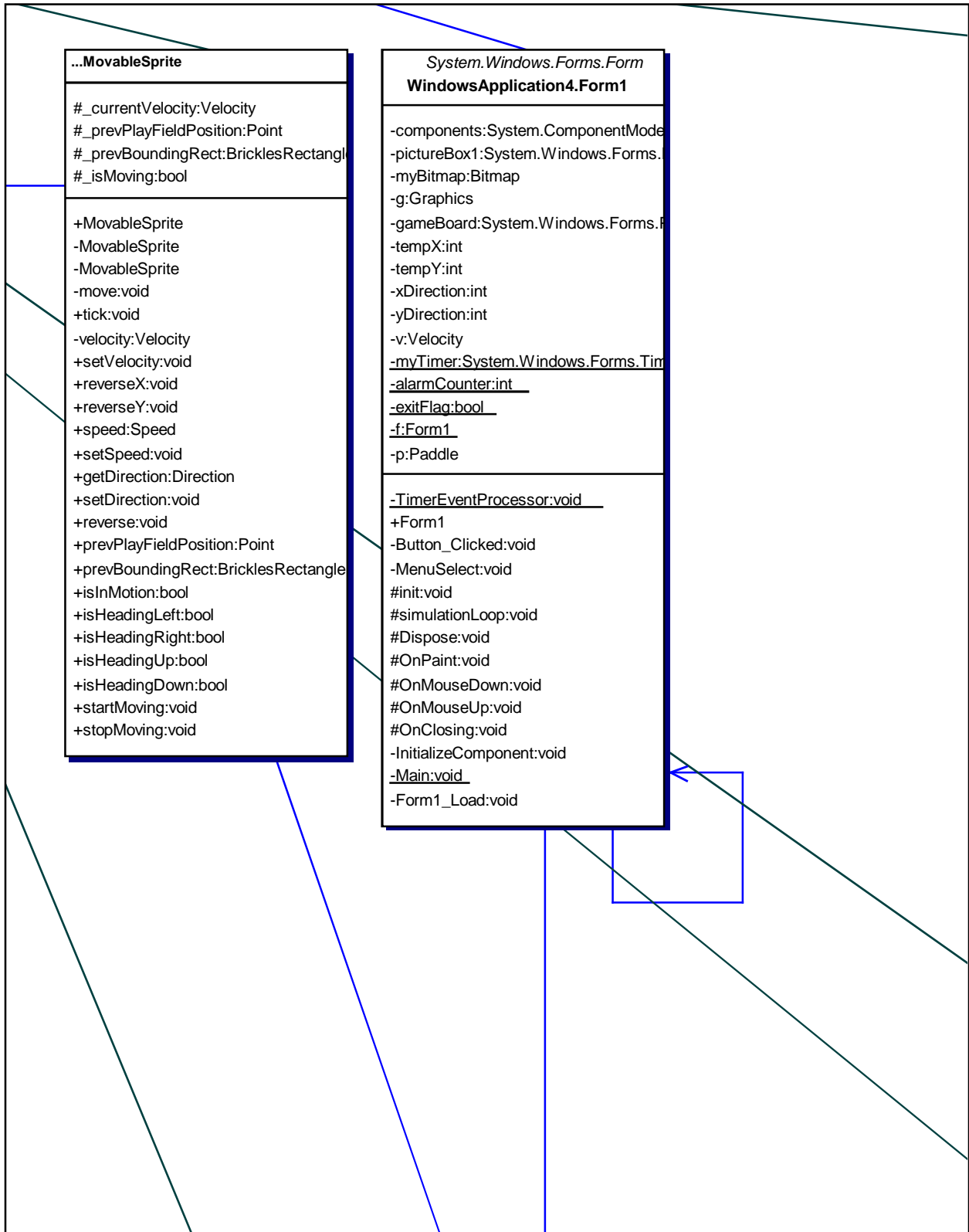

2.2, <default>

2.3, <default>

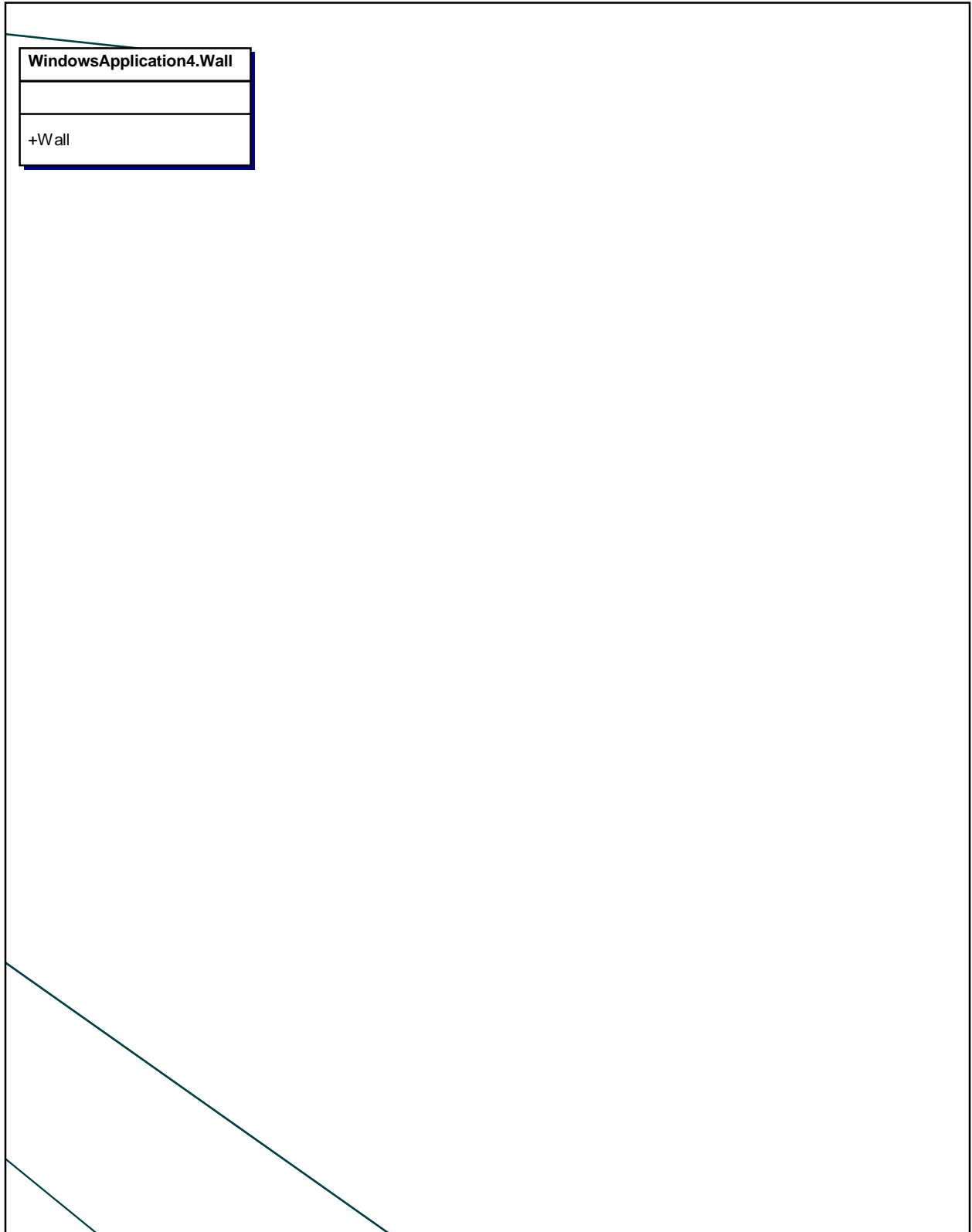

2.3, <default>

3.1, <default>

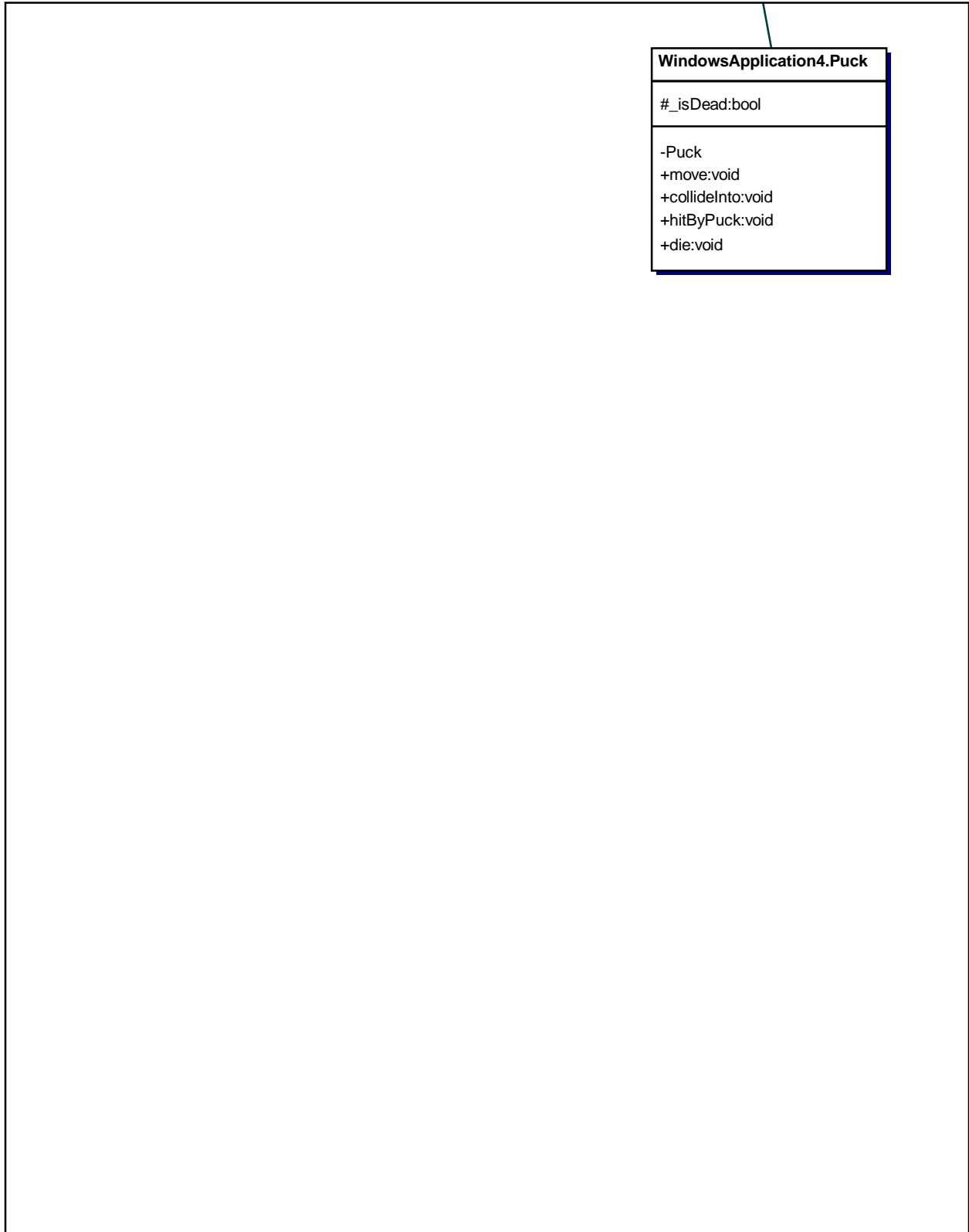

3.1, <default>

3.2, <default>

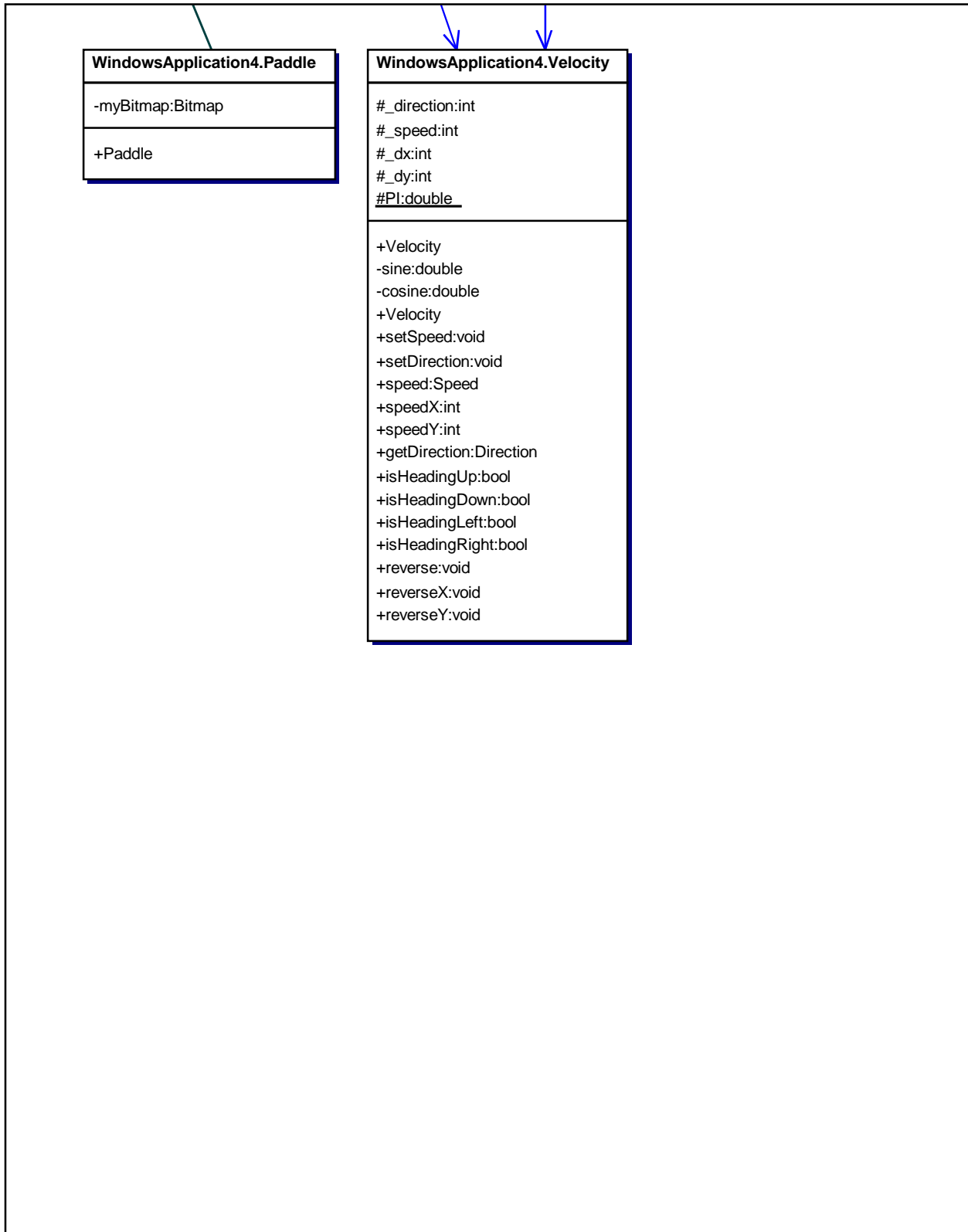

3.2, <default>

3.3, <default>

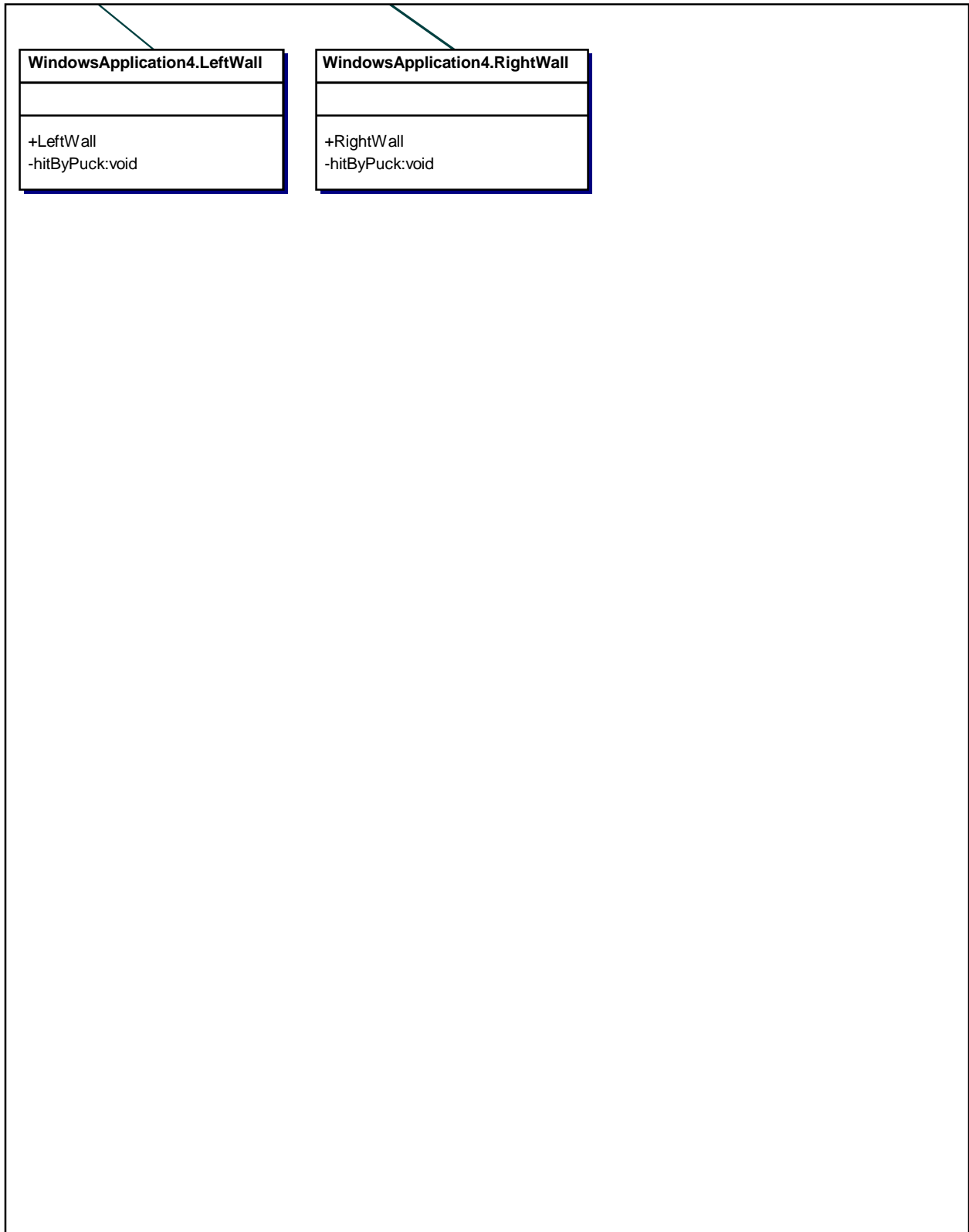

3.3, <default>

1.1, GameDefinitions

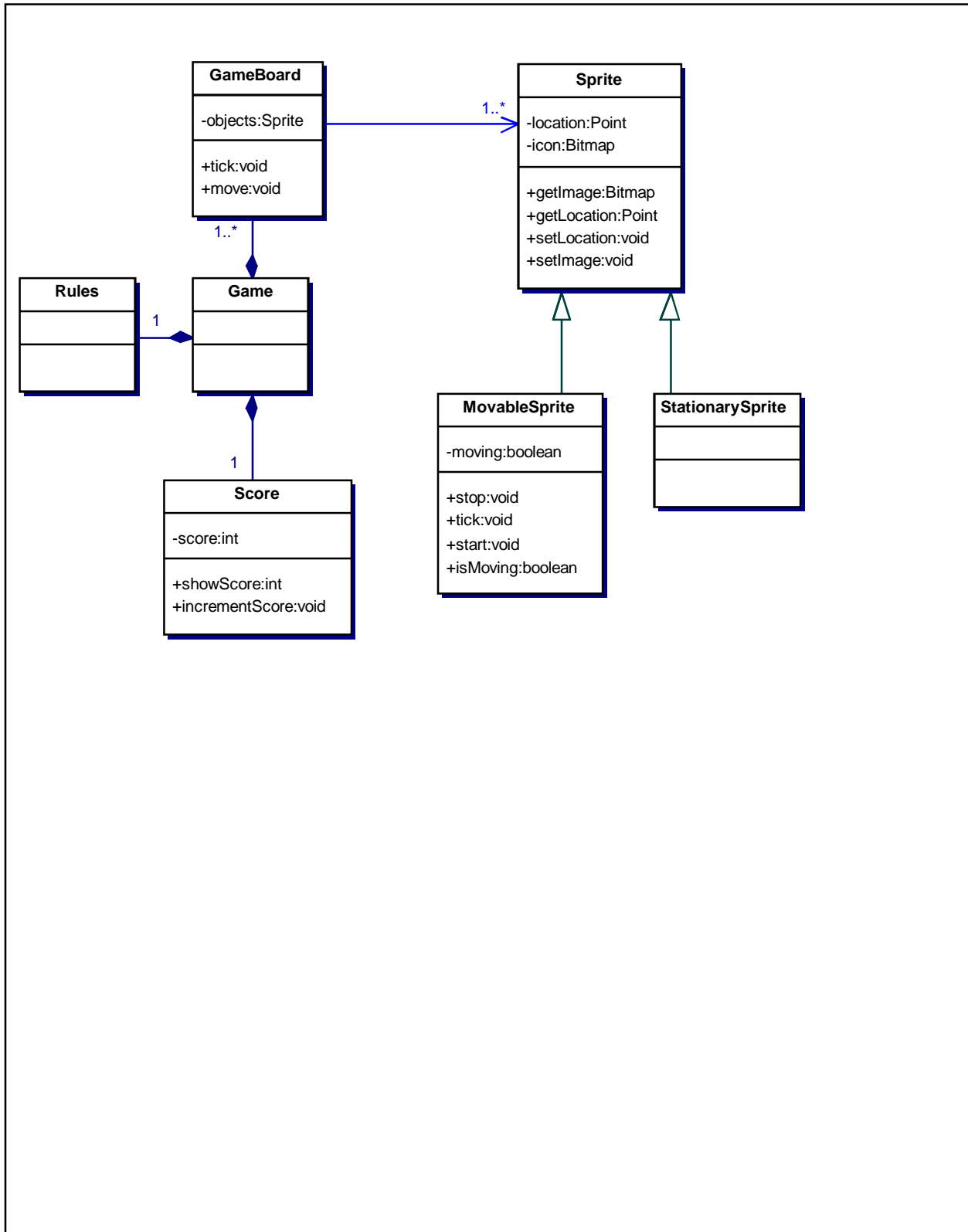

1.1, GameDefinitions

1.1, Sequence

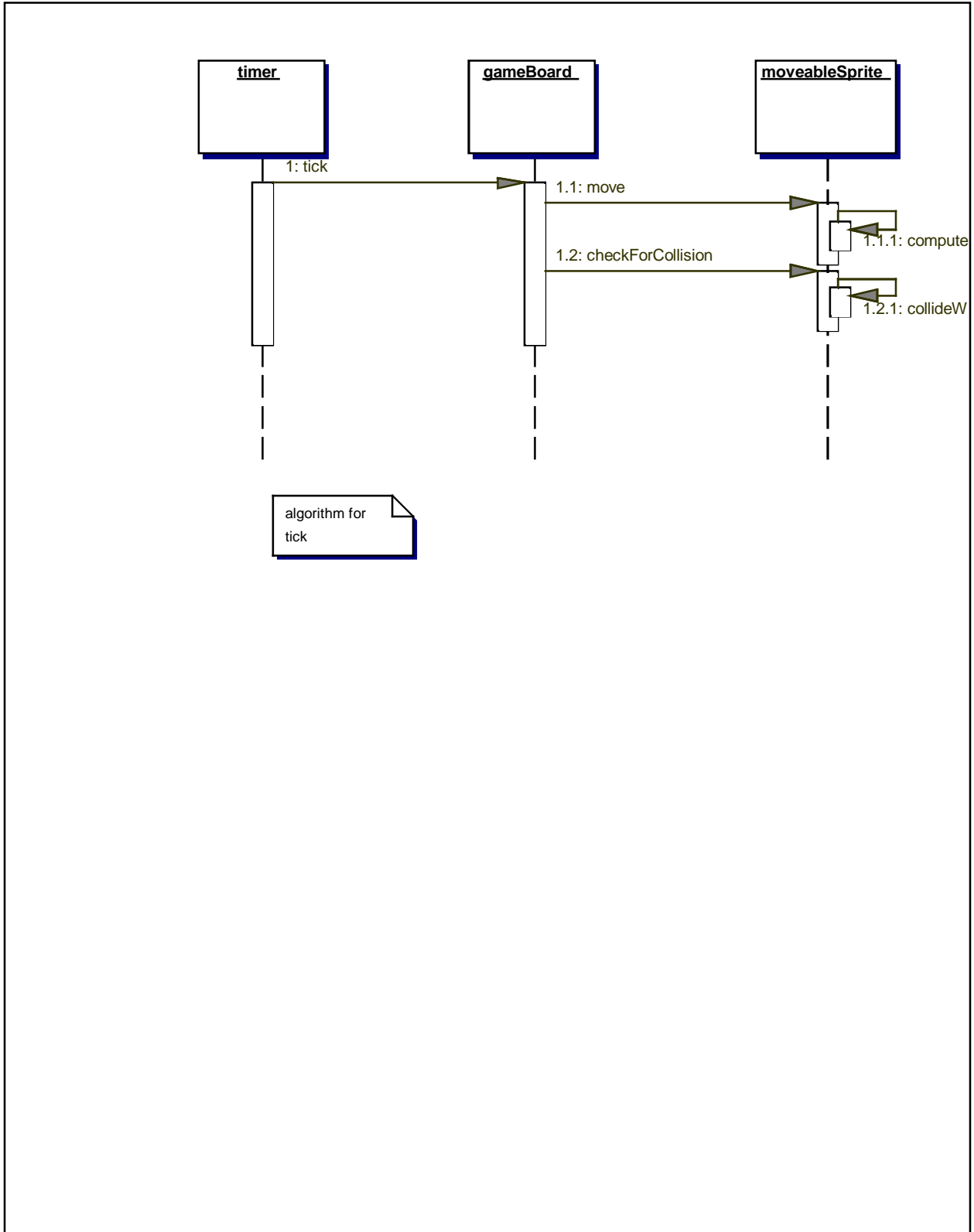

1.1, Sequence

1.2, Sequence

NewLocation

ith

1.2, Sequence

1.1, Statechart

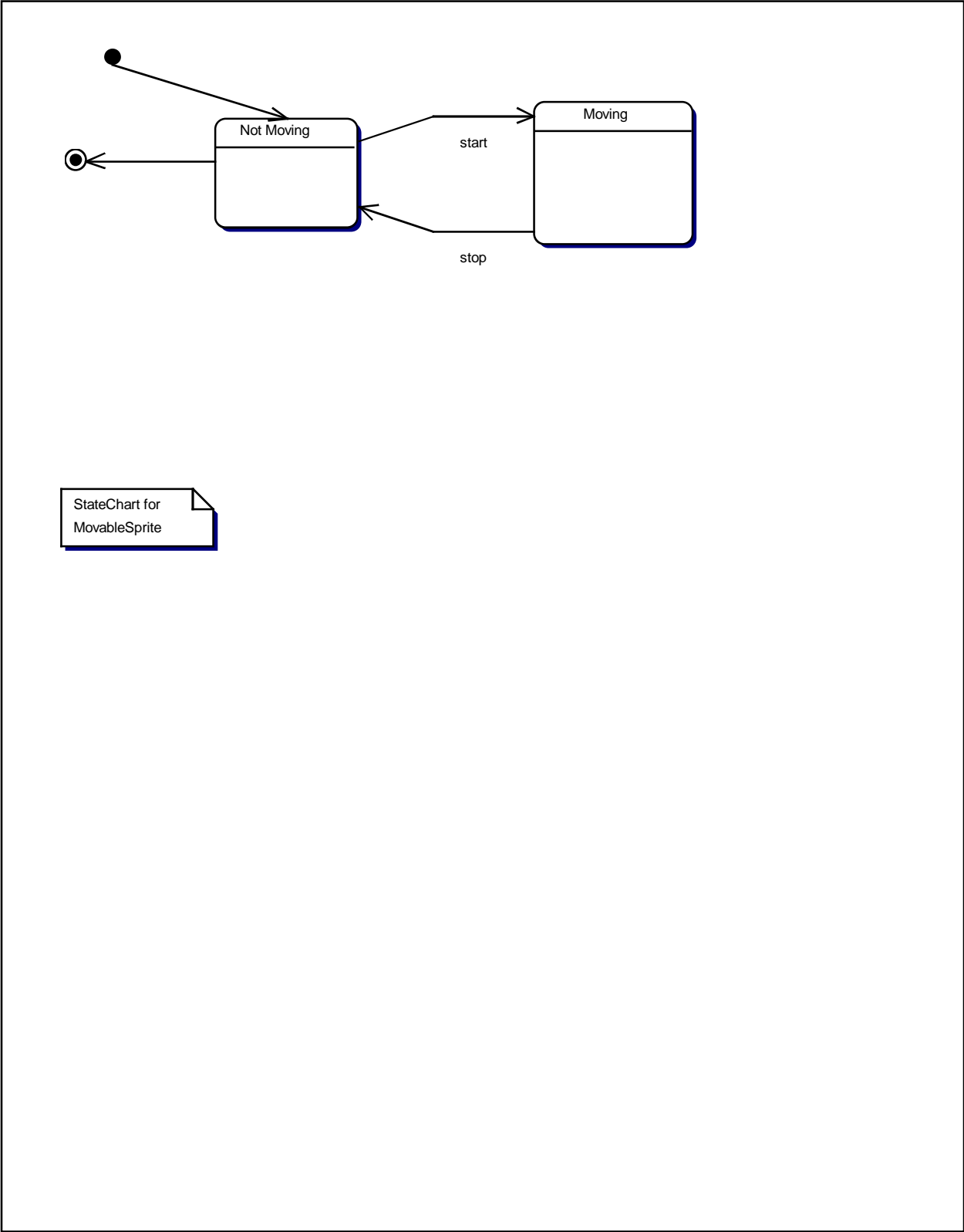

StateChart for MovableSprite

1.1, System Use Cases

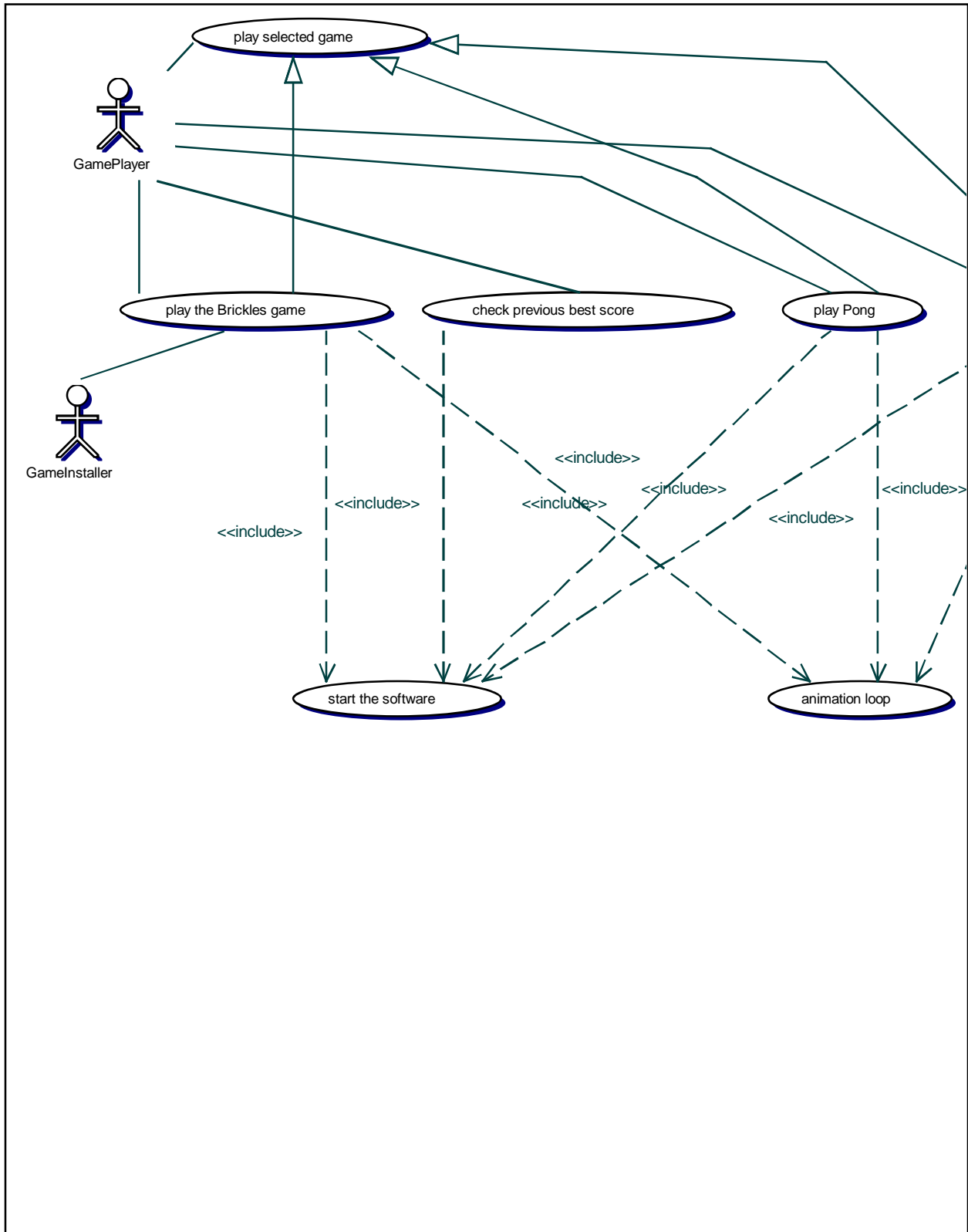

1.1, System Use Cases

1.2, System Use Cases

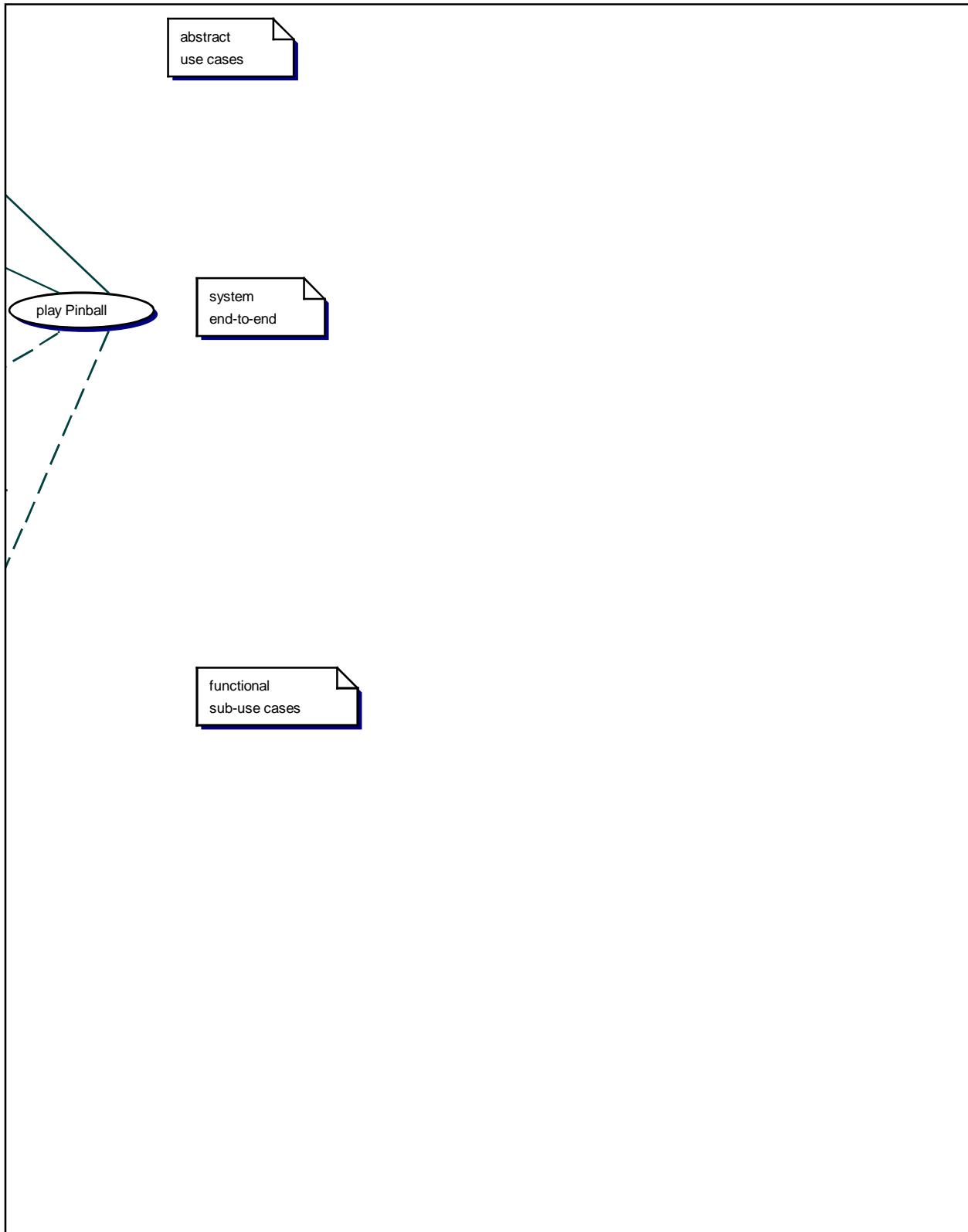

1.2, System Use Cases

1.1, JUnit

