

Adaptive Cruise Control

Overview

Adaptive cruise control (ACC) is an expansion of existing cruise control systems, designed to maintain vehicle speed through a link in the vehicle's powertrain. The advanced features of ACC systems include:

- > Links into the braking system through special actuator values to provide up to 20% of maximum vehicle braking force
- > Ability to track a car in the lane ahead using forward looking radar. If the distance to a vehicle in front is below a pre-set value, the ACC system is designed to slow the car down, using brakes if required, to track the speed of the vehicle in front, then returning the car to its pre-set speed once the lane ahead is clear
- > Steering angle and yaw rate sensors detect lanes and predict road curves, ensuring any vehicle in front is in the same lane as the subject car

One of the potential advantages of ACC is the foundation it provides for next generation advancements in lane detection systems, eventually expected to include cameras. The use of cameras in the vehicle is predicted to help provide for better lane following and collision avoidance by controlling the steering mechanism of the vehicle. This feature is anticipated to be beneficial in urban areas with heavy stop-and-go traffic by functioning at low stop/start speeds in city traffic. This feature is also expected to have the ability to stop the car completely when sitting in traffic, re-starting and following the car in front when the traffic begins to move again.

Key Benefits

- > Reduces the rate of auto accidents for vehicles fitted with collision avoidance systems
- > Reduces driver fatigue
- > Increases fuel efficiency due to gradual in-traffic speed increases and decreases
- > Interconnects to future, advanced systems

ADAPTIVE CRUISE CONTROL BLOCK DIAGRAM

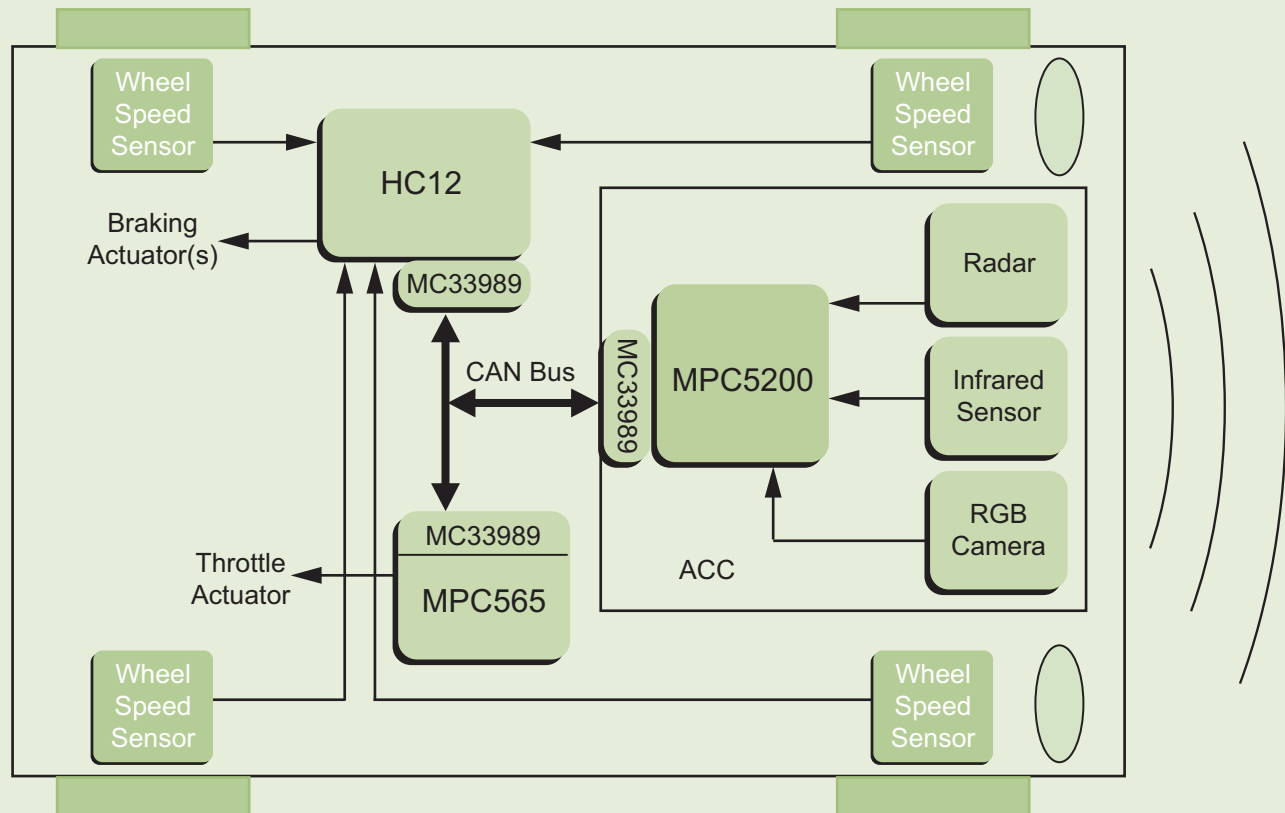

Freescale Ordering Information

Part Number	Product Highlights	Additional Information
MC33989	System Base Chip with high-speed CAN	www.freescale.com ^{Note}
MPC5200	Provides a cycle multiply accumulate (MAC)	
MPC565	32-bit microcontroller	

Note: Search on listed part number.

Design Challenges

One of the biggest challenges in designing ACC systems today is the costs associated with the robust system. Although current costs are substantial,

they are slowly decreasing. Some of the costs may include an integrated radar unit with digital signal processing (DSP) capabilities, as well as the adaptation of brake actuators. As ACC systems

increase in popularity and eventually become standard, an economy of scale will be realized with lower overall system costs.

Freescale Semiconductor Solution

The MPC500 Family by Freescale Semiconductor is an established automotive architecture with an extensive family of devices. It offers the MPC5200, which has a cycle multiply accumulate (MAC). The device is expected to be qualified for automotive requirements at 85°C. This device is also

designed to perform at 200+ MHz, easily capable of handling mid-range applications. The MPC4200, illustrated in the Figure on page 2, is connected to an auto-net via controller area network (CAN); the physical layer chips, like the MC33989, are also depicted. The Freescale Semiconductor HC12 device is engineered to read wheel speeds and

is an anti-lock braking system (ABS) controller. The MPC565 serves as the engine controller and could also accommodate throttle control functions on board. Any combination of infrared radar and a red, green, blue (RGB) camera is ideal for an ACC system.

Development Tools

Tool Type	Product Name	Vendor
Hardware/Software	Contact vendor	Accelerated Technologies, Inc.
Hardware/Software	Contact vendor	ASH WARE Inc.
Hardware/Software	Contact vendor	Ashling Microsystems Ltd.
Hardware/Software	Contact vendor	Green Hills Software
Hardware/Software	Contact vendor	iSystems
Hardware/Software	Contact vendor	Lauterbach
Hardware/Software	Contact vendor	Metrowerks
Hardware/Software	Contact vendor	PHYTEC
Hardware/Software	Contact vendor	Vector
Hardware/Software	Contact vendor	Wind River Systems
Development Kit	Contact vendor	Axiom

Notes

Learn More: Contact the Technical Information Center at +1-800-521-6247 or +1-480-768-2130.
For more information about Freescale products, please visit www.freescale.com.

Freescale™ and the Freescale logo are trademarks of Freescale Semiconductor, Inc.
All other product or service names are the property of their respective owners.
© Freescale Semiconductor, Inc. 2004. All rights reserved.

SG2025
REV 2
12/2004

December2004

