

1. Consider the MIPS “load word” instruction as implemented on the datapath above (Figure 4.2 from textbook):

```
lw R2, 8(R1) // Reg[2] <- memory[ Reg[1] + 8 ]
```

Circle the correct value 0 or 1 for the control signals (a-d) and circle whether each of the three muxes (e-g) selects its upper input, lower input, or don't care. For the ALU operation (h) circle one of the function names. (The Zero condition signal will be assumed to be 0.) (24 pts.)

- | | |
|--------------------|---|
| (a) Branch = 0 1 | (e) Mux1 (upper left; output to PC) = upper, lower, don't care |
| (b) MemRead = 0 1 | (f) Mux2 (upper middle; output to Data port of Regs) = upper, lower, don't care |
| (c) MemWrite = 0 1 | (g) Mux3 (lower middle; output to bottom leg of ALU) = upper, lower, don't care |
| (d) RegWrite = 0 1 | (h) ALU operation = and, or, add, subtract, set-on-less-than, nor |

2. Consider the MIPS “store word” instruction as implemented on the datapath above (Figure 4.2 from textbook):

```
sw R4, -12(R3) // Memory[ Reg[3] + signextended(-12) ] <- Reg[4]
```

Circle the correct value 0 or 1 for the control signals (a-d) and circle whether each of the three muxes (e-g) selects its upper input, lower input, or don't care. For the ALU operation (h) circle one of the function names. (The Zero condition signal will be assumed to be 0.) (24 pts.)

- | | |
|--------------------|---|
| (a) Branch = 0 1 | (e) Mux1 (upper left; output to PC) = upper, lower, don't care |
| (b) MemRead = 0 1 | (f) Mux2 (upper middle; output to Data port of Regs) = upper, lower, don't care |
| (c) MemWrite = 0 1 | (g) Mux3 (lower middle; output to bottom leg of ALU) = upper, lower, don't care |
| (d) RegWrite = 0 1 | (h) ALU operation = and, or, add, subtract, set-on-less-than, nor |

3. Consider the following datapath. (Assume all registers are edge-triggered and thus immune from races.) Control signal identifiers are given for the “in” and “out” control points of the registers. Additional control signals include memory signals Mem, R (read), W (write), and 3-bit ALU function field F. (A, B, and C are internal buses.)

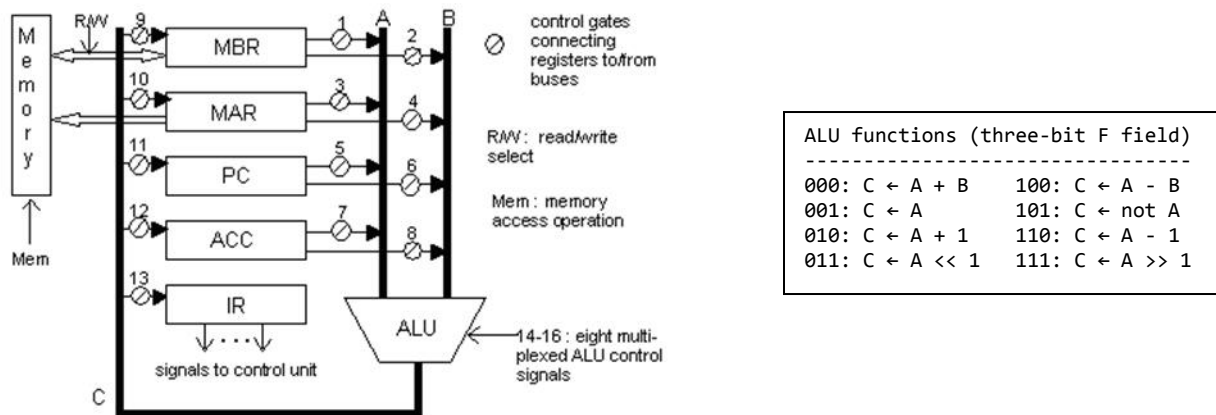

Complete the step-by-step RTL and the control signal sequence to fetch and execute an increment accumulator instruction “incr”. Assume that the instruction is composed of a one-word opcode. Assume also that the address of the instruction is in the PC, and that the memory is word-addressable. The action of the instruction is $ACC \leftarrow ACC + 1$ (12 pts.)

```
// fetch opcode and place in IR
MAR ← PC
PC ← PC + 1
MBR ← memory[MAR]
IR ← MBR

// increment accumulator
...

// control signals
5 (A←PC),      F=001 (C←A),      10 (MAR←C)
5 (A←PC),      F=010 (C←A+1),  11 (PC←C)
Mem/R
1 (A←MBR),     F=001 (C←A),      13 (IR←C)
```

4. Complete the step-by-step RTL and the control signal sequence to fetch and execute a decrement memory instruction “decr A”. Assume that the instruction is composed of two memory words: a one-word opcode followed by a one-word address. Assume also that the address of the instruction is in the PC, and that the memory is word-addressable. The action of the instruction is $\text{memory}[A] \leftarrow \text{memory}[A] - 1$, for the memory address A given in the second word of the instruction. (Does not change the value held in the ACC.) (40 pts.)

```
// fetch opcode and place in IR
MAR ← PC
PC ← PC + 1
MBR ← memory[MAR]
IR ← MBR

// fetch operand address and place in MBR
MAR ← PC
PC ← PC + 1
MBR ← memory[MAR]

// fetch operand and place into MBR
...

// decrement MBR
...

// store updated MBR back into memory at operand address
...

// control signals
5 (A←PC),      F=001 (C←A),      10 (MAR←C)
5 (A←PC),      F=010 (C←A+1),  11 (PC←C)
Mem/R
1 (A←MBR),     F=001 (C←A),      13 (IR←C)

5 (A←PC),      F=001 (C←A),      10 (MAR←C)
5 (A←PC),      F=010 (C←A+1),  11 (PC←C)
Mem/R
```